

E2K-C

Adjustable Long-distance Sensor

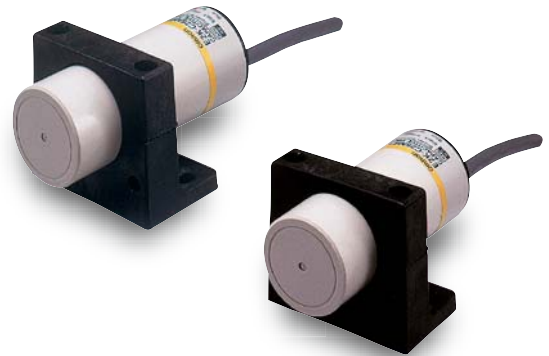



- Detects both metallic and nonmetallic objects (water, plastic, etc.).
- CE Marking for DC 3-Wire and AC/DC 2-Wire Models.
- Noise-resistant Models added to the lineup for application in a wide range of industrial environments.



 Be sure to read *Safety Precautions* on page 7.

Ordering Information

Sensors

Appearance		Sensing distance			Model		
					Output configuration	Operation mode	
						NO	NC
Standard Models	Unshielded  34 dia.	 3 to 25 mm	DC 3-wire, NPN	E2K-C25ME1	E2K-C25ME2		
			AC 2-wire	E2K-C25MY1	E2K-C25MY2		
Noise-resistant Models	 34 dia.	 3 to 20 mm	DC 3-wire, NPN	E2K-C20MC1	E2K-C20MC2		
			AC/DC 2-wire	E2K-C20MT1	E2K-C20MT2		

Accessories (Order Separately)

Mounting Brackets

Appearance	Model	Quantity	Remarks
	Y92E-A34	1	Provided with the product.

Ratings and Specifications

Standard Models

Item	Model	E2K-C25ME1	E2K-C25ME2	E2K-C25MY1	E2K-C25MY2
Sensing distance*		25 mm			
Sensing area		3 to 25 mm			
Detectable object		Conductors and dielectrics			
Standard sensing object		Grounded metal plate: 50 × 50 × 1 mm			
Differential travel		15% max. of sensing distance (when adjusted to 25 mm ±10% with standard sensing object)			
Response frequency		70 Hz		10 Hz	
Power supply voltage (operating voltage range)		12 to 24 VDC (10 to 40 VDC), ripple (p-p): 10% max.		100 to 220 VAC (90 to 250 VAC), 50/60 Hz	
Current consumption		E Models: 10 mA max. at 12 VDC, 16 mA max. at 24 VDC			
Leakage current		Y Models: 1 mA max. at 100 VAC (50/60 Hz) with output turned OFF, 2 mA max. at 200 VAC (50/60 Hz) with output turned OFF			
Control output	Load current	200 mA max.		5 to 200 mA (resistive load)	
	Residual voltage	2 V max. (Load current: 200 mA, Cable length: 2 m)		Refer to <i>Engineering Data</i> on page 4.	
Indicators		Detection indicator (red)		Operation indicator (red)	
Operation mode (with sensing object approaching)		E1/Y1 Models: NO E2/Y2 Models: NC Refer to the timing charts under <i>I/O Circuit Diagrams</i> on page 5 for details.			
Protection circuits		Reverse polarity protection, Surge suppressor		Surge suppressor	
Ambient temperature range		Operating/Storage: -25 to 70°C (with no icing or condensation)			
Ambient humidity range		Operating/Storage: 35% to 95% (with no condensation)			
Temperature influence		±15% max. of sensing distance at 23°C in the temperature range of -10 to 55°C ±25% max. of sensing distance at 23°C in the temperature range of -25 to 70°C			
Voltage influence		±2% max. of sensing distance at the rated voltage in rated voltage ±15% range		±2% max. of sensing distance at the rated voltage in rated voltage +20%, -10% range at 100 VAC, ±20% range at 200 VAC	
Insulation resistance		50 MΩ min. (at 500 VDC) between current-carrying parts and case			
Dielectric strength		1,000 VAC, 50/60 Hz for 1 min between current-carrying parts and case		1,500 VAC, 50/60 Hz for 1 min between current-carrying parts and case	
Vibration resistance		Destruction: 10 to 55 Hz, 1.5-mm double amplitude for 2 hours each in X, Y, and Z directions			
Shock resistance		Destruction: 500 m/s ² 10 times each in X, Y, and Z directions			
Degree of protection		IEC 60529 IP66			
Connection method		Pre-wired Models (Standard cable length: 2 m)			
Weight (packed state)		Approx. 200 g			
Materials	Case	Heat-resistant ABS			
	Sensing surface				
Accessories		Mounting Bracket, Instruction manual			

* The set distances are sensing distances applicable to standard sensing objects. Refer to *Engineering Data* on page 4 for other materials.

Noise-resistant Models

Item	Model	E2K-C20MC1	E2K-C20MC2	E2K-C20MT1	E2K-C20MT2
Sensing distance *1		20 mm			
Sensing area		3 to 20 mm			
Detectable object		Conductors and dielectrics			
Standard sensing object		Grounded metal plate: 50 × 50 × 1 mm			
Differential travel		15% max. of sensing distance (when adjusted to 20 mm ±10% with standard sensing object)			
Response frequency *2		40 Hz		AC power: 25 Hz, DC power: 40 Hz	
Power supply voltage (operating voltage range)		12 to 24 VDC (10 to 36 VDC), ripple (p-p): 10% max.		24 to 240 VAC (20 to 250 VAC), 50/60 Hz; 24 to 240 VDC (20 to 250 VDC)	
Current consumption		13 mA max. at 24 VDC		---	
Leakage current		---		1.5 mA max. at 24 VDC, 1.7 mA max. at 110 VAC (50/60 Hz), 2.5 mA max. at 250 VAC (50/60 Hz) Refer to <i>Engineering Data</i> on page 4.	
Control output	Load current	250 mA max.		5 to 200 mA (resistive load)	
	Residual voltage	2.5 V max. (Load current: 250 mA, Cable length: 2 m)		AC power: 10 V max., DC power: 8 V max. Refer to <i>Engineering Data</i> on page 4.	
Indicators		Operation indicator (yellow)			
Operation mode (with sensing object approaching)		C1/T1 Models: NO C2/T2 Models: NC Refer to the timing charts under <i>I/O Circuit Diagrams</i> on page 5 for details.			
Protection circuits		Reverse polarity protection, Load short-circuit protection		---	
Ambient temperature range		Operating/Storage: -25 to 70°C (with no icing or condensation)			
Ambient humidity range		Operating/Storage: 35% to 95% (with no condensation)			
Temperature influence		±15% max. of sensing distance at 23°C in the temperature range of -10 to 55°C ±25% max. of sensing distance at 23°C in the temperature range of -25 to 70°C			
Voltage influence		±2% max. of sensing distance at the rated voltage in rated voltage ±15% range			
Insulation resistance		50 MΩ min. (at 500 VDC) between current-carrying parts and case			
Dielectric strength		1,000 VAC, 50/60 Hz for 1 min between current-carrying parts and case		1,500 VAC, 50/60 Hz for 1 min between current-carrying parts and case	
Vibration resistance		Destruction: 10 to 55 Hz, 1.5-mm double amplitude for 2 hours each in X, Y, and Z directions			
Shock resistance		Destruction: 500 m/s ² 10 times each in X, Y, and Z directions			
Degree of protection		IEC 60529 IP65			
Connection method *3		Pre-wired Models (Standard cable length: 2 m)			
Weight (packed state)		Approx. 240 g			
Materials	Case	PBT			
	Sensing surface	PBT			
Accessories		Mounting Bracket, Instruction manual			

*1. The set distances are sensing distances applicable to standard sensing objects. Refer to *Engineering Data* on page 4 for other materials.

*2. The response frequency is an average value.

*3. Only 2-m cables are available. Use a cable with a conductor cross section of 0.5 mm² or greater to extend the cable.

Sensing Area (Grounded Metal Plate)

E2K-C25M□□

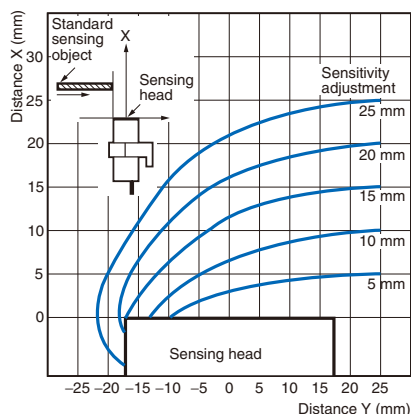

Sensing Object Size vs. Sensing Distance

E2K-C25M□□

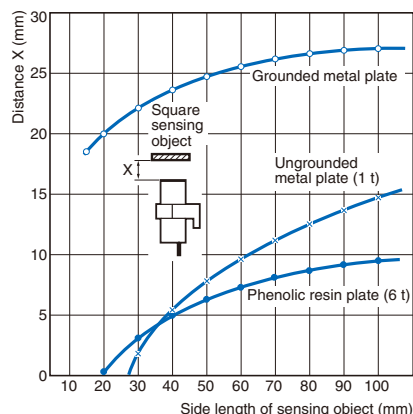

Sensing area

E2K-C20M□□

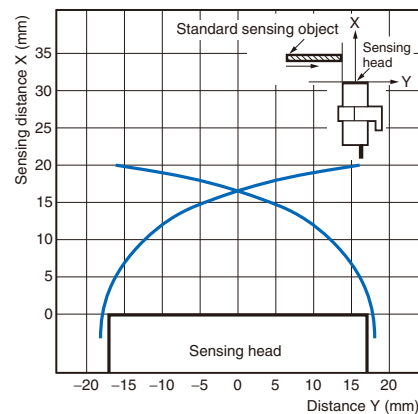

I/O Circuit Diagrams

DC 3-Wire Models

Operation mode	Model	Timing chart	Output circuit
NO	E2K-C25ME1	<p>Sensing object: Present (High), Not present (Low)</p> <p>Load (between brown and black leads): Operate (High), Reset (Low)</p> <p>Output voltage (between black and blue leads): High, Low</p> <p>Detection indicator (red): ON, OFF</p>	<p>*1. Load current: 200 mA max. *2. When a transistor is connected.</p>
NC	E2K-C25ME2	<p>Sensing object: Present (High), Not present (Low)</p> <p>Load (between brown and black leads): Operate (High), Reset (Low)</p> <p>Output voltage (between black and blue leads): High, Low</p> <p>Detection indicator (red): ON, OFF</p>	<p>*1. Load current: 200 mA max. *2. When a transistor is connected.</p>
NO	E2K-C20MC1	<p>Sensing object: Present (High), Not present (Low)</p> <p>Load (between brown and black leads): Operate (High), Reset (Low)</p> <p>Operation Indicator (yellow): ON, OFF</p>	<p>* Load current: 250 mA max.</p>
NC	E2K-C20MC2	<p>Sensing object: Present (High), Not present (Low)</p> <p>Load (between brown and black leads): Operate (High), Reset (Low)</p> <p>Operation Indicator (yellow): ON, OFF</p>	<p>* Load current: 250 mA max.</p>

AC 2-Wire Models

Operation mode	Model	Timing chart	Output circuit
NO	E2K-C25MY1		
NC	E2K-C25MY2		

AC/DC 2-Wire Models

Operation mode	Model	Timing chart	Output circuit
NO	E2K-C20MT1		<p>* Load current: 200 mA max.</p>
NC	E2K-C20MT2		

Dimensions

Sensors

E2K-C25M□□

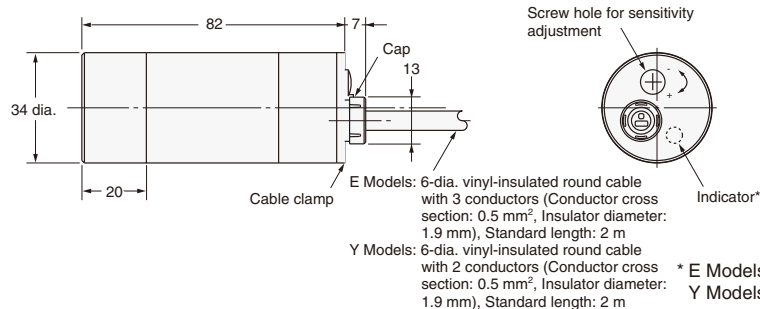
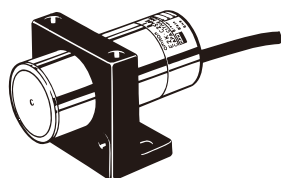

* E Models: Detection indicator (red)
Y Models: Operation indicator (red)

E2K-C20M□□

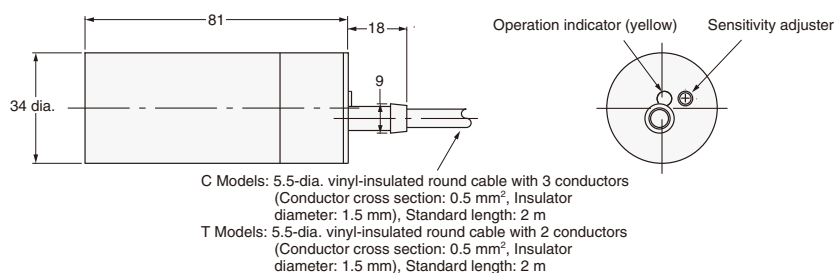

Accessories (Order Separately)

Mounting Bracket (Accessory)

Y92E-A34

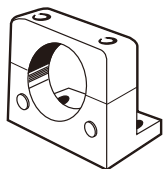

Material: Polyacetal

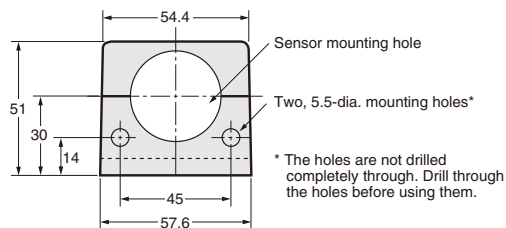
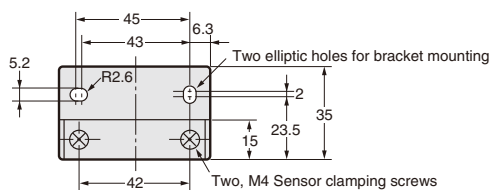

With Mounting Bracket Attached

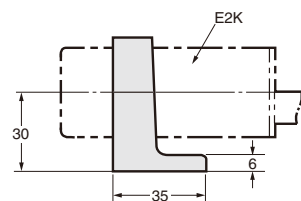

Note: Provided with the product.