







**Safety position switch, narrow, 1N/O+1N/C, insulated material, + actuator ZB**

**Part no.** LS4/S11-1/I/ZB  
**Article no.** 106857  
**Catalog No.** LS4-S11-1-I-ZB

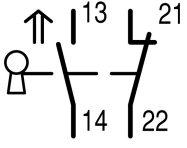
**Delivery programme**

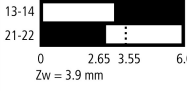
Basic function			Position switches Safety position switches
Part group reference			LS(4)...ZB
Product range			Safety position switches
Degree of Protection			IP65
Features			Complete unit
Ambient temperature		°C	-25 - +70
Description			With the actuator inserted, the N/O contact is open and the NC contact is closed.
Approval			
<b>Contacts</b>			
N/O = Normally open			1 N/O
N/C = Normally closed			1 NC 
Notes			 = safety function, by positive opening to IEC/EN 60947-5-1
Contact sequence			
Contact travel  = Contact closed  = Contact open			
Housing			Insulated material
Connection type			Screw terminal
<b>Notes</b> Do not, under any circumstance, use the switch as a mechanical stop or transportation restraint or brace! Connect operating elements permanently with the protective device, e.g., with non-reusable screws or rivets. Operating head can be rotated 90°.			

**Technical data**

<b>General</b>			
Standards			IEC/EN 60947
Climatic proofing			Damp heat, constant, to IEC 60068-2-78; damp heat, cyclical, to IEC 60068-2-30
Ambient temperature		°C	-25 - +70
Mounting position			As required
Degree of Protection			IP65
Terminal capacities		mm <sup>2</sup>	
Solid		mm <sup>2</sup>	1 x (0.75 - 2.5) 2 x (0.75 - 1.5)
Flexible with ferrule		mm <sup>2</sup>	1 x (0.5 - 1.5) 2 x (0.5 - 1.5)
Terminal screw			PH1
Tightening torque for terminal screw		Nm	0.9

**Contacts/switching capacity**

Rated impulse withstand voltage	$U_{imp}$	V AC	6000
Rated insulation voltage	$U_i$	V	500
Overvoltage category/pollution degree			III/3
Rated operational current	$I_e$	A	

AC-15			
24 V	I <sub>e</sub>	A	6
220 V 230 V 240 V	I <sub>e</sub>	A	6
380 V 400 V 415 V	I <sub>e</sub>	A	4
DC-13			
24 V	I <sub>e</sub>	A	3
110 V	I <sub>e</sub>	A	0.8
220 V	I <sub>e</sub>	A	0.3
Supply frequency		Hz	max. 400
Short-circuit rating to IEC/EN 60947-5-1			
max. fuse		A gG/gL	10
Repetition accuracy		mm	0.02
Rated conditional short-circuit current		kA	1

### Mechanical variables

Lifespan, mechanical	Operations	x 10 <sup>6</sup>	1.5
Mechanical shock resistance (half-sinusoidal shock, 20 ms)			
Standard-action contact		g	5
Operating frequency	Operations/h		 1800

### Actuation

Mechanical			
Actuating force at beginning/end of stroke		N	15/20 (plug-in/pull-out)

## Design verification as per IEC/EN 61439

Technical data for design verification			
Rated operational current for specified heat dissipation	I <sub>n</sub>	A	6
Heat dissipation per pole, current-dependent	P <sub>vid</sub>	W	0.1
Equipment heat dissipation, current-dependent	P <sub>vid</sub>	W	0
Static heat dissipation, non-current-dependent	P <sub>vs</sub>	W	0
Heat dissipation capacity	P <sub>diss</sub>	W	0
Operating ambient temperature min.		°C	-25
Operating ambient temperature max.		°C	70
IEC/EN 61439 design verification			
10.2 Strength of materials and parts			
10.2.2 Corrosion resistance			Meets the product standard's requirements.
10.2.3.1 Verification of thermal stability of enclosures			Meets the product standard's requirements.
10.2.3.2 Verification of resistance of insulating materials to normal heat			Meets the product standard's requirements.
10.2.3.3 Verification of resistance of insulating materials to abnormal heat and fire due to internal electric effects			Meets the product standard's requirements.
10.2.4 Resistance to ultra-violet (UV) radiation			Meets the product standard's requirements.
10.2.5 Lifting			Does not apply, since the entire switchgear needs to be evaluated.
10.2.6 Mechanical impact			Does not apply, since the entire switchgear needs to be evaluated.
10.2.7 Inscriptions			Meets the product standard's requirements.
10.3 Degree of protection of ASSEMBLIES			Does not apply, since the entire switchgear needs to be evaluated.
10.4 Clearances and creepage distances			Meets the product standard's requirements.
10.5 Protection against electric shock			Does not apply, since the entire switchgear needs to be evaluated.
10.6 Incorporation of switching devices and components			Does not apply, since the entire switchgear needs to be evaluated.
10.7 Internal electrical circuits and connections			Is the panel builder's responsibility.
10.8 Connections for external conductors			Is the panel builder's responsibility.
10.9 Insulation properties			
10.9.2 Power-frequency electric strength			Is the panel builder's responsibility.
10.9.3 Impulse withstand voltage			Is the panel builder's responsibility.
10.9.4 Testing of enclosures made of insulating material			Is the panel builder's responsibility.
10.10 Temperature rise			The panel builder is responsible for the temperature rise calculation. Eaton will provide heat dissipation data for the devices.

10.11 Short-circuit rating		Is the panel builder's responsibility. The specifications for the switchgear must be observed.
10.12 Electromagnetic compatibility		Is the panel builder's responsibility. The specifications for the switchgear must be observed.
10.13 Mechanical function		The device meets the requirements, provided the information in the instruction leaflet (IL) is observed.

## Technical data ETIM 6.0

Sensors (EG000026) / End switch (EC000030)		
Electric engineering, automation, process control engineering / Binary sensor technology, safety-related sensor technology / Position switch / Position switch (Type 1) (ecl@ss8.1-27-27-06-01 [AGZ382012])		
Width sensor	mm	40
Diameter sensor	mm	0
Height of sensor	mm	125
Length of sensor	mm	40
Rated operation current I <sub>e</sub> at AC-15, 24 V	A	10
Rated operation current I <sub>e</sub> at AC-15, 125 V	A	6
Rated operation current I <sub>e</sub> at AC-15, 230 V	A	6
Rated operation current I <sub>e</sub> at DC-13, 24 V	A	3
Rated operation current I <sub>e</sub> at DC-13, 125 V	A	0.8
Rated operation current I <sub>e</sub> at DC-13, 230 V	A	0.3
Switching function		Slow-action switch
Output electronic		No
Forced opening		Yes
Number of safety auxiliary contacts		0
Number of contacts as normally closed contact		0
Number of contacts as normally open contact		0
Number of contacts as change-over contact		0
Type of interface		None
Type of interface for safety communication		None
Housing according to norm		-
Construction type housing		Cuboid
Material housing		Plastic
Coating housing		-
Type of control element		-
Alignment of the control element		-
Type of electric connection		Cable entry metrical
With status indication		No
Suitable for safety functions		Yes
Explosion safety category for gas		None
Explosion safety category for dust		None
Ambient temperature during operating	°C	-25 - 70
Degree of protection (IP)		IP65

## Approvals

Product Standards		IEC/EN 60947-5; UL 508; CSA-C22.2 No. 14; CE marking
UL File No.		E29184
UL Category Control No.		NKCR
CSA File No.		12528
CSA Class No.		3211-03
North America Certification		UL listed, CSA certified
Degree of Protection		IEC: IP65, UL/CSA Type 3R, 4X (indoor use only), 12, 13

# Dimensions

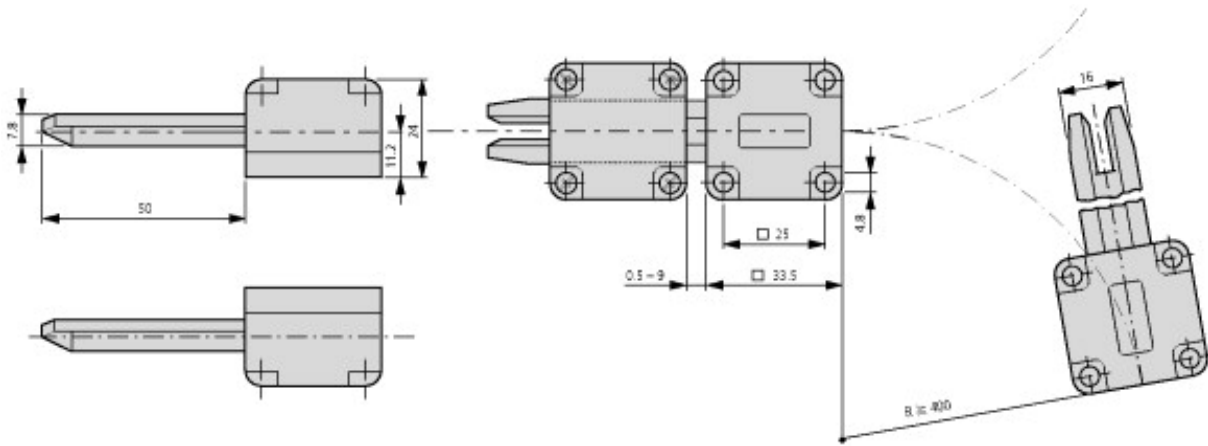
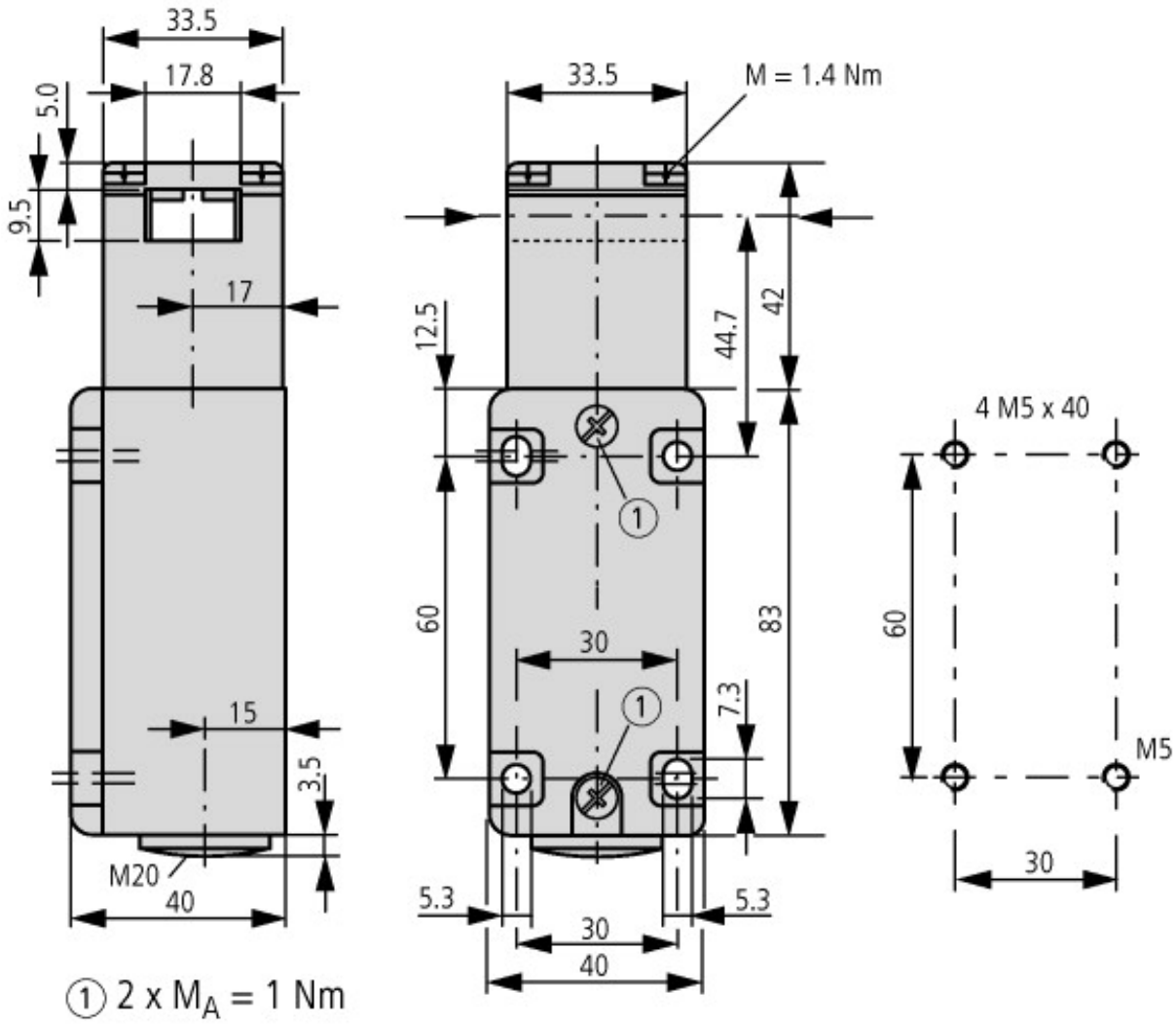

Switch must not be used as a mechanical stop

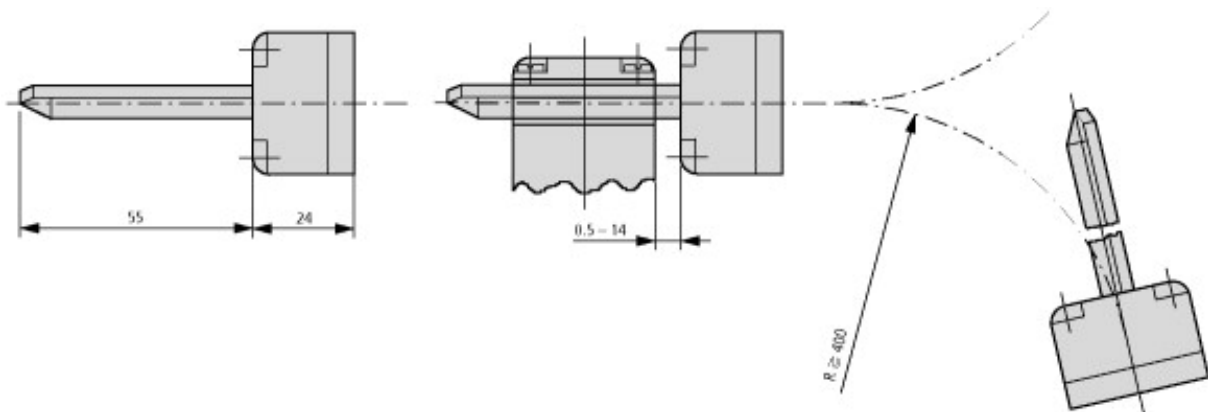

Actuator

## Additional product information (links)

IL05208004Z (AWA1310-2367) Safety position switch

IL05208004Z (AWA1310-2367) Safety position switch [ftp://ftp.moeller.net/DOCUMENTATION/AWA\\_INSTRUCTIONS/IL05208004Z2012\\_12.pdf](ftp://ftp.moeller.net/DOCUMENTATION/AWA_INSTRUCTIONS/IL05208004Z2012_12.pdf)