

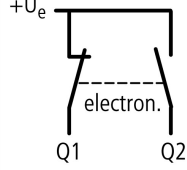
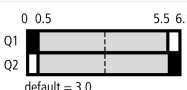
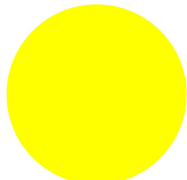

Safety position switch, electrically adjustable, 1N/O+1N/C, cat .3

Part no. LSE-11
Article no. 266121
Catalog No. LSE-11

Delivery programme

Basic function			Position switches Safety position switches
Part group reference			LSE
Product range			Position switch with electronically adjustable operating point
Degree of Protection			IP66, IP67
Features			Basic device, expandable
Ambient temperature		°C	-25 - +70
Description			Visual status indication comparable with positive opening function Device goes into safe state on high interference. Can be used in safety circuits partly short-circuit proof Restart after reset Individual operating point adjustment
Approval			
Contacts			
N/O = Normally open			1 N/O
N/C = Normally closed			1 NC
Contact sequence			+U _e  0 V
Contact travel: <input checked="" type="checkbox"/> = Contact closed <input type="checkbox"/> = Contact open			
Rated voltage	U _e	V DC	12 - 30
Colour			
Enclosure covers			Yellow
Enclosure covers			
Housing			Insulated material
Connection type			Cage Clamp
Notes			Cage-Clamp is a registered trademark of Wago Kontakttechnik, 32432 Minden, Germany. Accessories for the Cage-Clamp terminals from Wago: power comb, gray, Wago Article No. 264-402

Technical data

General			
Standards			IEC/EN 60947 EN 61000-4

Climatic proofing			Damp heat, constant, to IEC 60068-2-78; damp heat, cyclical, to IEC 60068-2-30
Ambient temperature		°C	-25 - +70
Mounting position			As required
Degree of Protection			IP66, IP67
Terminal capacities		mm ²	
Solid		mm ²	1 x (0.5 - 2.5)
Flexible with ferrule		mm ²	1 x (0.5 - 1.5)



Power supply

Rated voltage	U _e	V DC	12 - 30
Rated operational current	I _e	A	
12 V	I _e	A	0.015
24 V	I	mA	18
30 V	I	A	0.019

Contacts/switching capacity

Overvoltage category/pollution degree			III/3
Rated operational current	I _e	A	
DC-13			
24 V	I _e	A	0.2
Repetition accuracy		mm	0.02

Mechanical variables

Lifespan, mechanical	Operations	x 10 ⁶	3
Notes			(electronic)
Contact temperature of roller head		°C	 100
Mechanical shock resistance (half-sinusoidal shock, 20 ms)			
Basic unit		g	30
Operating frequency	Operations/h		 3000
Switching point			0.5 - 5.5 mm, freely adjustable
Hysteresis		mm	0.4
Contact sequence (contact closed open Zw = positive opening clearance)		mm	0.04

Actuation

Mechanical			
Actuating force at beginning/end of stroke		N	3.5/8.0
Actuating torque of rotary drives		Nm	0.2
Max. operating speed with DIN cam		m/s	1/0.5
Notes			for angle of actuation α = 0°/30°

Electromagnetic compatibility (EMC)

Electrostatic discharge (IEC/EN 61000-4-2, Level 3, ESD)		kV	
Air discharge		kV	8
Contact discharge		kV	4
Electromagnetic fields (RFI) to IEC EN 61000-4-3		V/m	10
Burst Impulse (IEC/EN 61000-4-4, Level 3)			
Supply cable		kV	2
Signal lines		kV	2
Power pulses (surge) (IEC/EN 61000-4-5)		kV	0.5
Immunity to line-conducted interference to (IEC/EN 61000-4-6)		V	10

Design verification as per IEC/EN 61439

Technical data for design verification			
Heat dissipation capacity	P _{diss}	W	0
Operating ambient temperature min.		°C	-25
Operating ambient temperature max.		°C	70
IEC/EN 61439 design verification			
10.2 Strength of materials and parts			
10.2.2 Corrosion resistance			Meets the product standard's requirements.

10.2.3.1 Verification of thermal stability of enclosures		Meets the product standard's requirements.
10.2.3.2 Verification of resistance of insulating materials to normal heat		Meets the product standard's requirements.
10.2.3.3 Verification of resistance of insulating materials to abnormal heat and fire due to internal electric effects		Meets the product standard's requirements.
10.2.4 Resistance to ultra-violet (UV) radiation		Meets the product standard's requirements.
10.2.5 Lifting		Does not apply, since the entire switchgear needs to be evaluated.
10.2.6 Mechanical impact		Does not apply, since the entire switchgear needs to be evaluated.
10.2.7 Inscriptions		Meets the product standard's requirements.
10.3 Degree of protection of ASSEMBLIES		Does not apply, since the entire switchgear needs to be evaluated.
10.4 Clearances and creepage distances		Meets the product standard's requirements.
10.5 Protection against electric shock		Does not apply, since the entire switchgear needs to be evaluated.
10.6 Incorporation of switching devices and components		Does not apply, since the entire switchgear needs to be evaluated.
10.7 Internal electrical circuits and connections		Is the panel builder's responsibility.
10.8 Connections for external conductors		Is the panel builder's responsibility.
10.9 Insulation properties		
10.9.2 Power-frequency electric strength		Is the panel builder's responsibility.
10.9.3 Impulse withstand voltage		Is the panel builder's responsibility.
10.9.4 Testing of enclosures made of insulating material		Is the panel builder's responsibility.
10.10 Temperature rise		The panel builder is responsible for the temperature rise calculation. Eaton will provide heat dissipation data for the devices.
10.11 Short-circuit rating		Is the panel builder's responsibility. The specifications for the switchgear must be observed.
10.12 Electromagnetic compatibility		Is the panel builder's responsibility. The specifications for the switchgear must be observed.
10.13 Mechanical function		The device meets the requirements, provided the information in the instruction leaflet (IL) is observed.

Technical data ETIM 6.0

Sensors (EG000026) / End switch (EC000030)

Electric engineering, automation, process control engineering / Binary sensor technology, safety-related sensor technology / Position switch / Position switch (Type 1) (ecl@ss8.1-27-27-06-01 [AGZ382012])

Width sensor	mm	31
Diameter sensor	mm	0
Height of sensor	mm	61
Length of sensor	mm	33.5
Rated operation current I _e at AC-15, 24 V	A	0
Rated operation current I _e at AC-15, 125 V	A	0
Rated operation current I _e at AC-15, 230 V	A	0
Rated operation current I _e at DC-13, 24 V	A	0.2
Rated operation current I _e at DC-13, 125 V	A	0
Rated operation current I _e at DC-13, 230 V	A	0
Switching function		Slow-action switch
Output electronic		Yes
Forced opening		No
Number of safety auxiliary contacts		0
Number of contacts as normally closed contact		1
Number of contacts as normally open contact		1
Number of contacts as change-over contact		0
Type of interface		None
Type of interface for safety communication		None
Housing according to norm		-
Construction type housing		Cuboid
Material housing		Plastic
Coating housing		-
Type of control element		Plunger
Alignment of the control element		-
Type of electric connection		-
With status indication		Yes

Suitable for safety functions		Yes
Explosion safety category for gas		None
Explosion safety category for dust		None
Ambient temperature during operating	°C	-25 - 70
Degree of protection (IP)		IP67

Approvals

Product Standards		IEC/EN 60947-5; UL 508; CSA-C22.2 No. 14; CE marking
UL File No.		E29184
UL Category Control No.		NKCR
CSA File No.		12528
CSA Class No.		3211-03
North America Certification		UL listed, CSA certified
Degree of Protection		IEC: IP66, 67, UL/CSA Type 3R, 4X (indoor use only), 12, 13

Dimensions

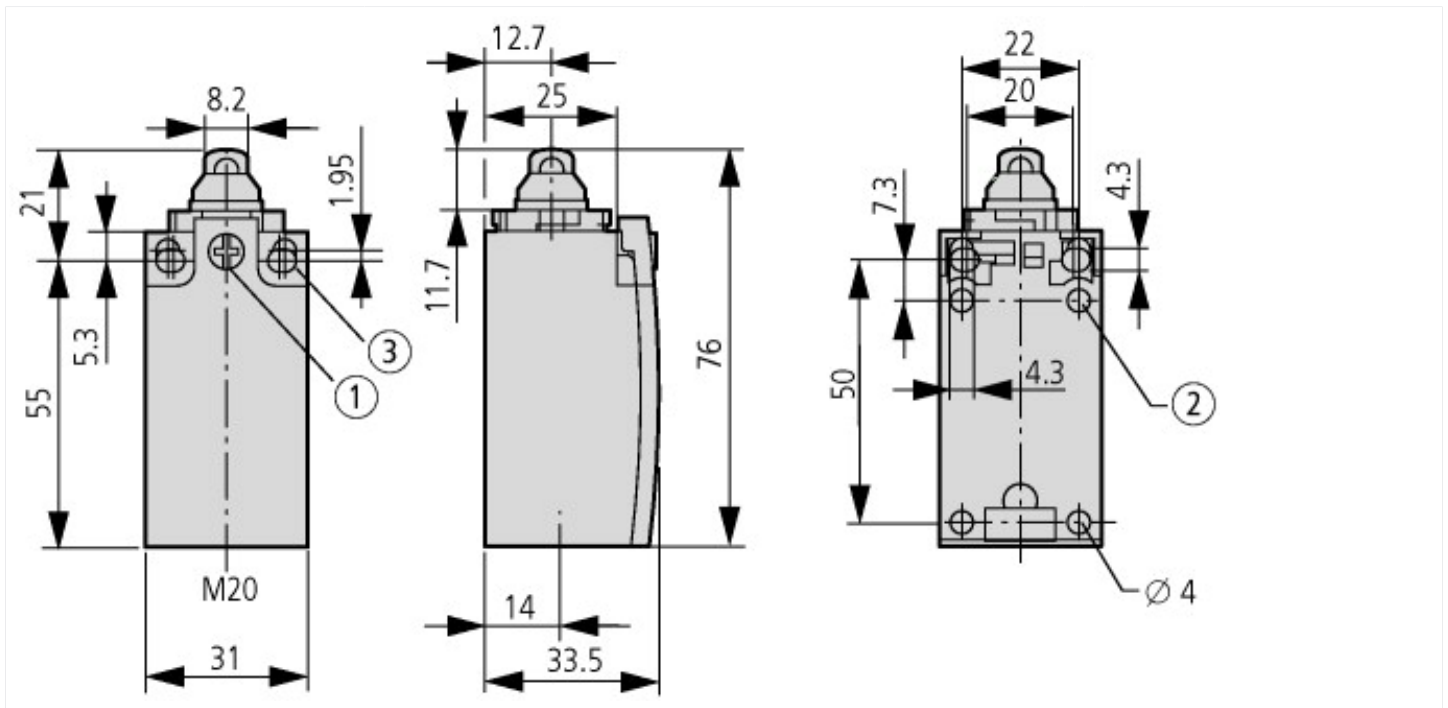

- ① Tightening torque of cover screws: 0.8 Nm \pm 0.2 Nm
- ② only with LS (insulated version)
- ③ Fixing screws 2 x M4 $\frac{11}{30}$
- $M_A = 1.5$ Nm

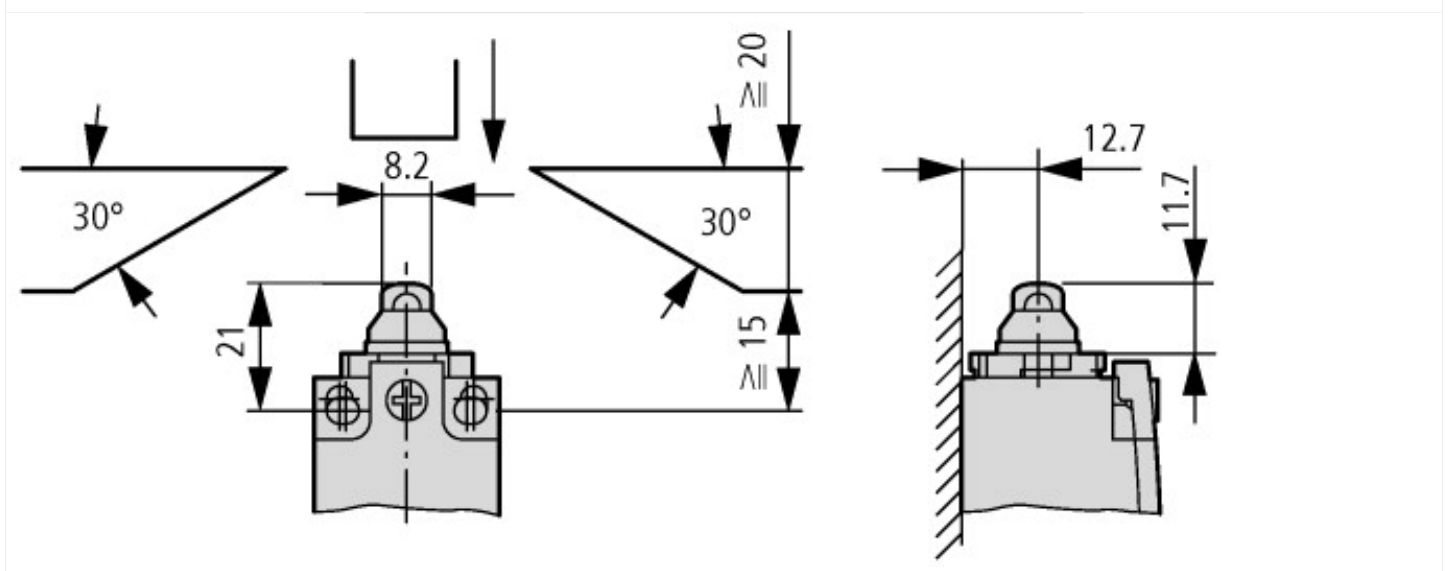

Additional product information (links)

IL05208001Z (AWA1310-2349) Electronic position switch

IL05208001Z (AWA1310-2349) Electronic
position switch

ftp://ftp.moeller.net/DOCUMENTATION/AWA_INSTRUCTIONS/IL05208001Z2012_08.pdf