



Digital input card for XC100/200, 24 V DC, 8DI

Part no. **XIOC-8DI**
 Article no. **257891**

Delivery programme

Function			Digital modules
Description			Compact I/O system for connection to XC100/200 Modular PLCs XC100/200 expandable with up to 15 XI/OC modules Optionally, screw terminals or spring-loaded terminals for digital/analog modules
			8 inputs, 24 V DC

Technical data



General

Standards			IEC/EN 61131-2 EN 50178
Ambient temperature		°C	0 - +55
Storage	θ	°C	-25 - +70
Vibration resistance			10 - 57 Hz ±0.075 mm 57 - 150 Hz ±1.0 mm
Mechanical shock resistance		g	15 Shock duration 11 ms
Impact resistance			500 g/  50 mm ±25 g
Overvoltage category/pollution degree			II/2
Protection class			1
Degree of Protection			IP20
Emitted interference			DIN/EN 55011/22, Class A
Weight		kg	0.16

Power supply

Rated voltage	U_e	V DC	24 (12)
Admissible range			20.4 – 28.8 (11.8 – 14.4)
Neutral poles			
Duration of dip		ms	10
Repetition rate		s	1
Residual ripple		%	 5
Maximum power loss	P_v	W	0.8

Inputs

Input type			DC input
Input voltage		V DC	24
Admissible range		V DC	20.4 - 28.8
Input current		mA	Normally 6.9
Input impedance			Normally 3.5 kΩ
Voltage level to IEC 61131-2, limit value type 1			
ON		V	 15 DC
OFF		V	 5 DC
Input delay			
Off → On		ms	
Debounce ON		ms	 5 (normally 4)
On → Off		ms	

Debounce ON		ms	≤ 5 (normally 4)
Input channels		Qty.	8
Channels with the same reference potential		Number	8
Potential isolation			Opto-isolated
Indicating elements			LED (green)
Terminals			Plug-in terminal block
		Number	
Internal current consumption (5 V DC)		mA	26

Outputs

Short-circuit protection			Yes
Short-circuit protection			Yes

Design verification as per IEC/EN 61439

Technical data for design verification			
Rated operational current for specified heat dissipation	I_n	A	0
Heat dissipation per pole, current-dependent	P_{vid}	W	0
Equipment heat dissipation, current-dependent	P_{vid}	W	0
Static heat dissipation, non-current-dependent	P_{vs}	W	0.8
Heat dissipation capacity	P_{diss}	W	0
Operating ambient temperature min.		°C	0
Operating ambient temperature max.		°C	55
IEC/EN 61439 design verification			
10.2 Strength of materials and parts			
10.2.2 Corrosion resistance			
Meets the product standard's requirements.			
10.2.3.1 Verification of thermal stability of enclosures			
Meets the product standard's requirements.			
10.2.3.2 Verification of resistance of insulating materials to normal heat			
Meets the product standard's requirements.			
10.2.3.3 Verification of resistance of insulating materials to abnormal heat and fire due to internal electric effects			
Meets the product standard's requirements.			
10.2.4 Resistance to ultra-violet (UV) radiation			
Meets the product standard's requirements.			
10.2.5 Lifting			
Does not apply, since the entire switchgear needs to be evaluated.			
10.2.6 Mechanical impact			
Does not apply, since the entire switchgear needs to be evaluated.			
10.2.7 Inscriptions			
Meets the product standard's requirements.			
10.3 Degree of protection of ASSEMBLIES			
Meets the product standard's requirements.			
10.4 Clearances and creepage distances			
Meets the product standard's requirements.			
10.5 Protection against electric shock			
Does not apply, since the entire switchgear needs to be evaluated.			
10.6 Incorporation of switching devices and components			
Does not apply, since the entire switchgear needs to be evaluated.			
10.7 Internal electrical circuits and connections			
Is the panel builder's responsibility.			
10.8 Connections for external conductors			
Is the panel builder's responsibility.			
10.9 Insulation properties			
10.9.2 Power-frequency electric strength			
Is the panel builder's responsibility.			
10.9.3 Impulse withstand voltage			
Is the panel builder's responsibility.			
10.9.4 Testing of enclosures made of insulating material			
Is the panel builder's responsibility.			
10.10 Temperature rise			
The panel builder is responsible for the temperature rise calculation. Eaton will provide heat dissipation data for the devices.			
10.11 Short-circuit rating			
Is the panel builder's responsibility.			
10.12 Electromagnetic compatibility			
Is the panel builder's responsibility.			
10.13 Mechanical function			
The device meets the requirements, provided the information in the instruction leaflet (IL) is observed.			

Approvals

Product Standards			IEC: see Technical Data; UL508; CSA-C22.2 No. 0-M; CSA-C22.2 No. 142-M; CE marking
UL File No.			E135462
UL Category Control No.			NRAQ
CSA File No.			012528
CSA Class No.			2252-01

North America Certification		UL listed, CSA certified
Specially designed for North America		No
Current Limiting Circuit-Breaker		No
Degree of Protection		IEC: IP20, UL/CSA Type: -

Dimensions

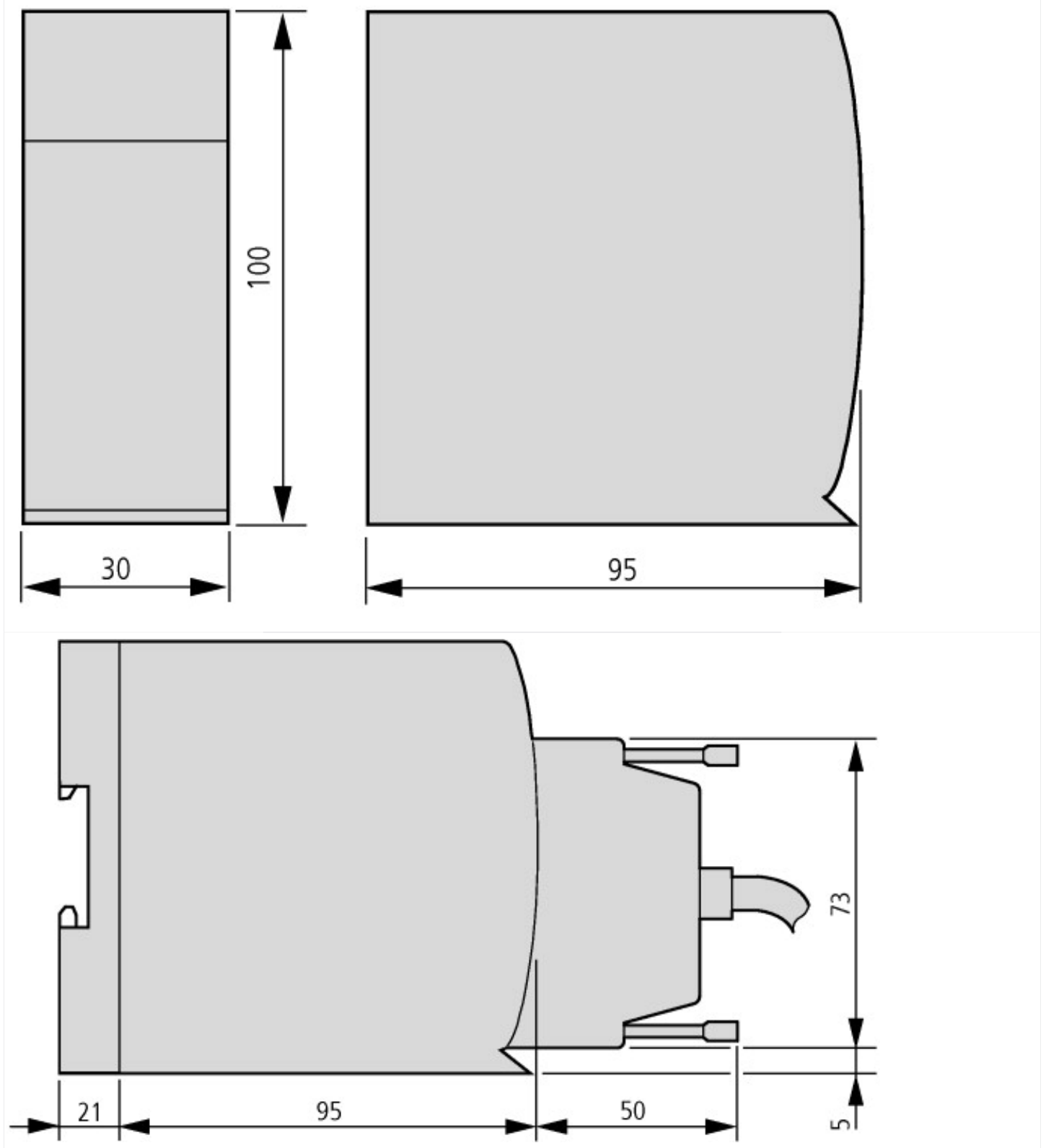

Additional product information (links)

MN05002002Z (AWB2725-1452) XIOC signal modules

MN05002002Z (AWB2725-1452) XIOC-Signalmodule - Deutsch

ftp://ftp.moeller.net/DOCUMENTATION/AWB_MANUALS/MN05002002Z_DE.pdf

MN05002002Z (AWB2725-1452) XIOC signal modules - English

ftp://ftp.moeller.net/DOCUMENTATION/AWB_MANUALS/MN05002002Z_EN.pdf

